

# 103-H89223-6341

SANYO DENKI  
SANMOTION

## Dimensions (Unit:mm)

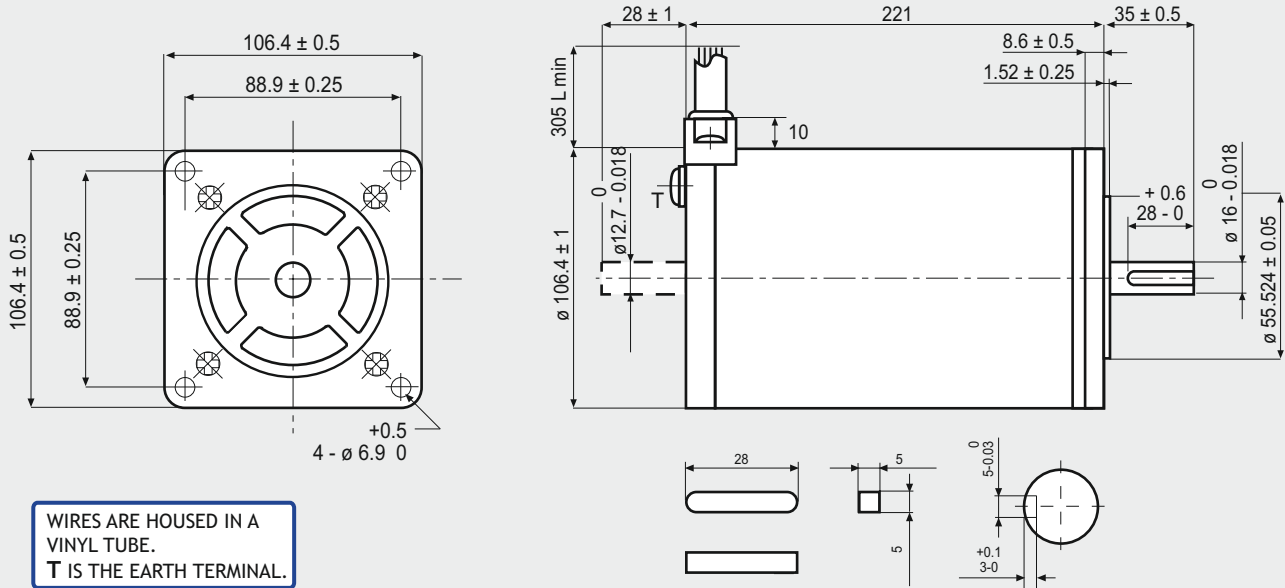

## FEATURES

MODEL	103-H89223-6341 (103-H89223-6311)	
BASIC STEP ANGLE	1.8° ± 0.09°	
BIPOLAR CURRENT	(Amp)	6.0
UNIPOLAR CURRENT	(Amp)	
RESISTANCE	(Ohm)	0.63
INDUCTANCE	(mH)	8.0
BIPOLAR HOLDING TORQUE	(Ncm)	2460
UNIPOLAR HOLDING TORQUE	(Ncm)	
ROTOR INERTIA	(Kg <sup>m</sup> 2 x 10 <sup>-7</sup> )	22000
THEORETICAL ACCELERATION	(rad x sec. <sup>-2</sup> )	11100
BACK E.M.F.	(V/Krpm)	410
MASS	(Kg)	10
PROTECTION DEGREE		IP43
LEADS CODE		V

Codes between brackets refer to double shaft models.

## TORQUE/SPEED CURVE

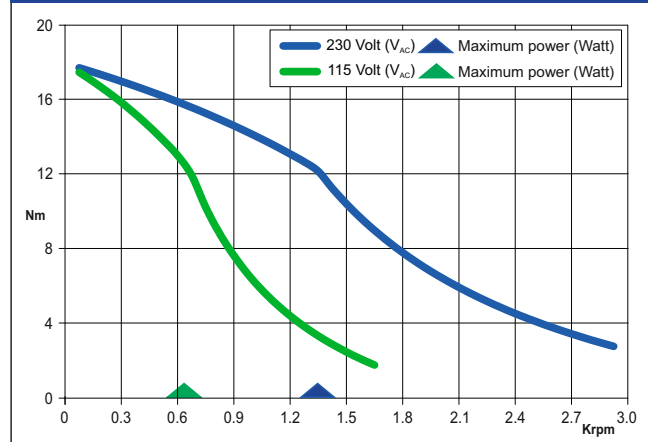

R.T.A. s.r.l. PAVIA (ITALY) SANYO DENKI CO., Ltd (JAPAN)



## Suggested R.T.A. drive model: X-MIND B6



R.T.A. s.r.l.  
Via E. Mattei - Fraz- Divisa  
27020 Marcignago (PV) (Italy)  
T +39.0382.929.855  
F +39.0382.929.150  
www.rta.it

R.T.A. Deutschland GmbH  
Bublitzer Strasse 34, 40599  
Duesseldorf (Germany)  
T +49.211.749.668.60  
F +49.211.749.668.66  
www.rta-deutschland.de

R.T.A. IBERICA  
C/Generalitat 22, Local 1  
08850 Gava - Barcelona (Spain)  
T +34 936.388.805  
F +34 936.334.595  
www.rta-iberica.es

R.T.A. INDIA Pvt  
Teerth Business Center 3<sup>rd</sup> Floor, Unit No. 7,  
Block EL-15, MIDC Bhosari Pimpri-Chinchwd,  
Pune 411026 (India)  
Tel. +91 9422507445  
www.rta-india.in